

## Injectors (4A-FE)

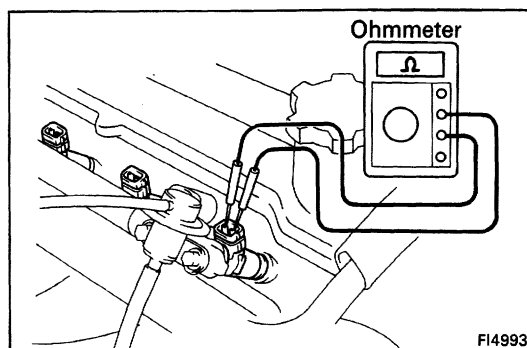
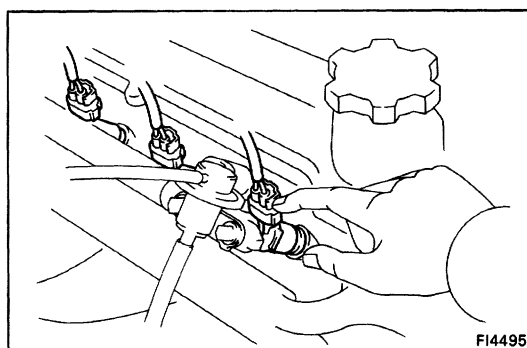
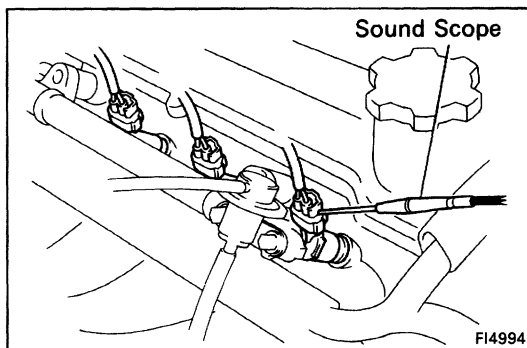
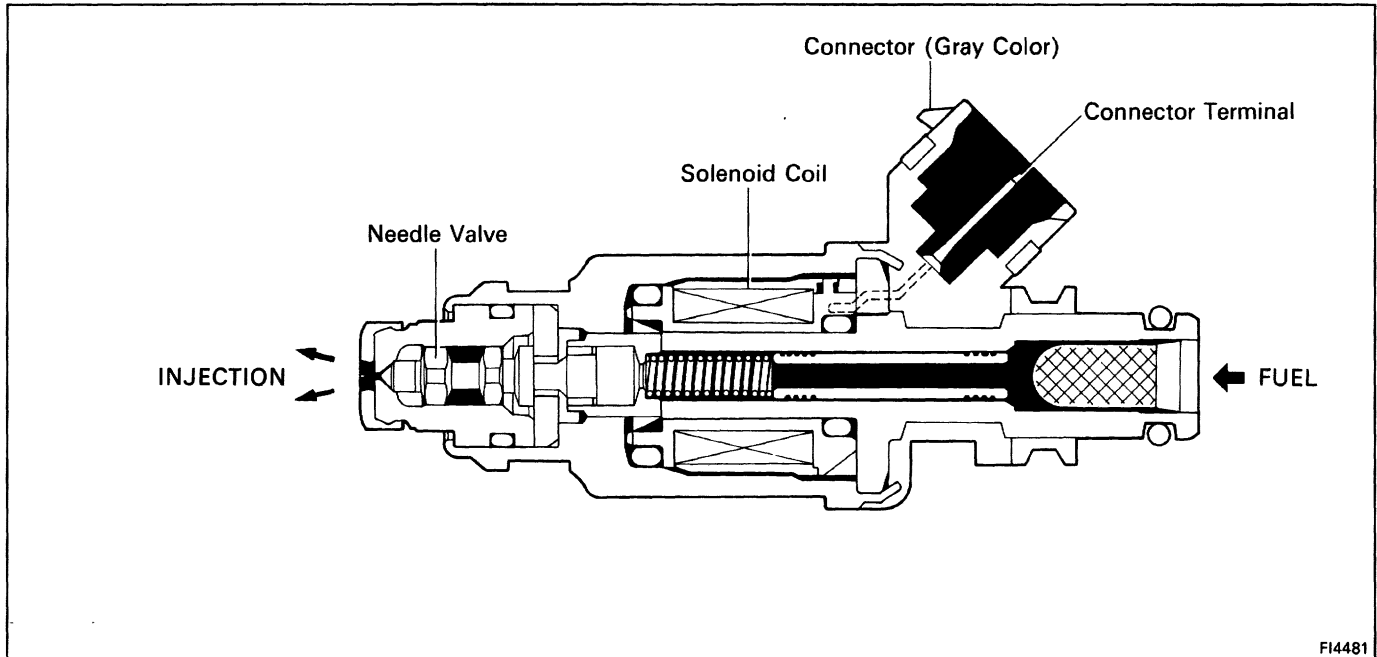

## ON-VEHICLE INSPECTION

### 1. INSPECT INJECTOR OPERATION

Check operation sound from each injector.

- (a) With the engine running or cranking, use a sound scope to check that there is normal operating noise in proportion to engine rpm.

- (b) If you have no sound scope, you can check the injector transmission operation with your finger.

If no sound or unusual sound is heard, check the wiring connector, injector or injection signal from the ECU.

### 2. INSPECT INJECTOR RESISTANCE

- (a) Disconnect the injector connector.
- (b) Using an ohmmeter, measure the resistance between the terminals.

**Resistance: Approx. 13.8Ω**

If the resistance is not as specified, replace the injector.

- (c) Reconnect the injector connector.

## REMOVAL OF INJECTORS

### 1. DISCONNECT CABLE FROM NEGATIVE TERMINAL OF BATTERY

**CAUTION:** Work must be started after approx. 20 seconds or longer from the time the ignition switch is turned to the "LOCK" position and the negative (-) terminal cable is disconnected from the battery.

### 2. DISCONNECT VACUUM SENSING HOSE FROM FUEL PRESSURE REGULATOR

### 3. DISCONNECT FUEL RETURN HOSE FROM FUEL PRESSURE REGULATOR

### 4. DISCONNECT INJECTOR CONNECTORS

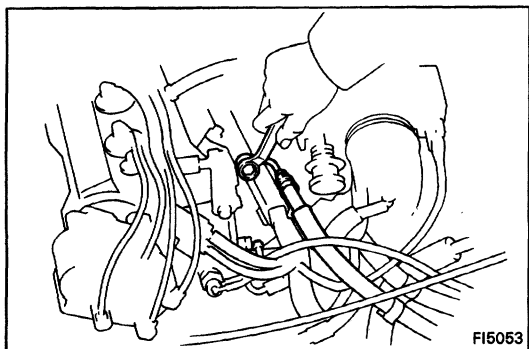

### 5. DISCONNECT FUEL INLET HOSE FROM DELIVERY PIPE

Remove the union bolt and two gaskets, and disconnect the inlet hose from the delivery pipe.

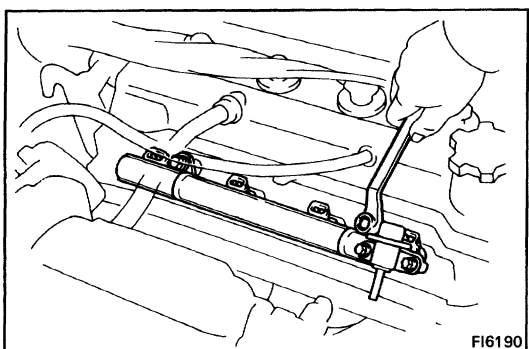

### 6. REMOVE DELIVERY PIPE AND INJECTORS

(a) Remove the two bolts and delivery pipe together with the four injectors.

**NOTICE:** Be careful not to drop the injectors when removing the delivery pipe.

(b) Remove the four insulators and two spacers from the cylinder head.

(c) Pull out the four injectors from the delivery pipe.

(d) Remove the O-ring and grommet from each injector.

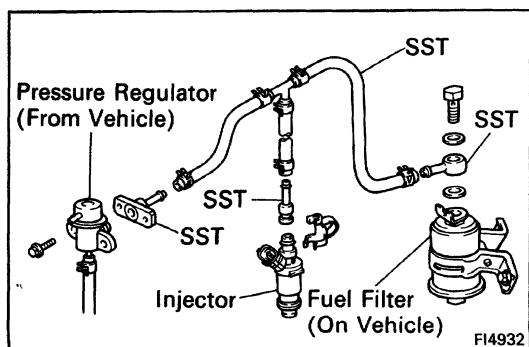

## INSPECTION OF INJECTORS

### 1. INSPECT INJECTOR INJECTION

**CAUTION:** Keep injector clear of sparks during the test.

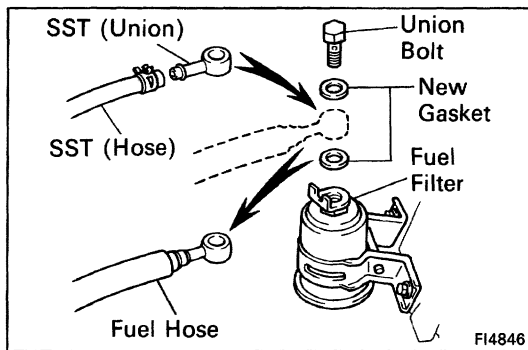

- (a) Disconnect the fuel hose from the fuel filter outlet.  
 (b) Connect SST (union and hose) to the fuel filter outlet with two new gaskets and the union bolt.  
 SST 09268-41045 (90405-09015)  
**Torque: 300 kg-cm (22 ft-lb, 29 N-m)**  
 HINT: Use the vehicle's fuel filter.

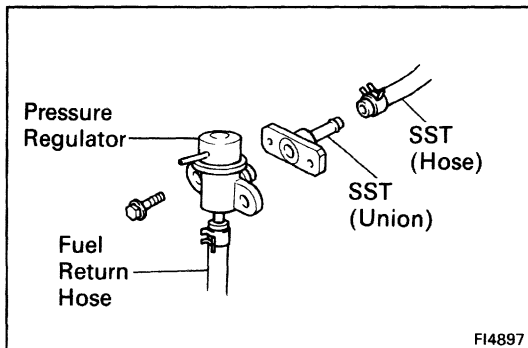

- (c) Remove the pressure regulator from the delivery pipe, and connect the fuel return hose to the pressure regulator.  
 (d) Install a new O-ring to the pressure regulator.  
 (e) Connect the SST (hose) to the pressure regulator with SST (union) and the two bolts.  
 SST 09268-41045 (09268-41090)  
**Torque: 95 kg-cm (82 in.-lb, 9.3 N-m)**

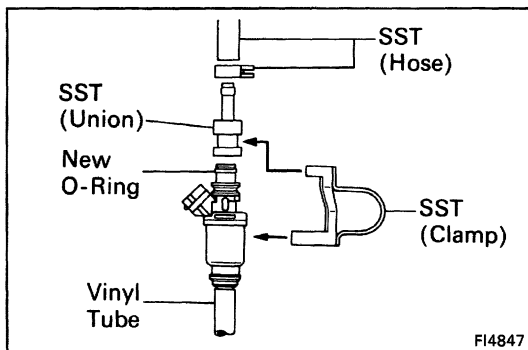

- (f) Install the grommet and a new O-ring to the injector.  
 (g) Connect SST (union and hose) to the injector, and hold the injector and union with SST (clamp).  
 SST 09268-41045  
 (h) Put the injector into the graduated cylinder.  
 HINT: Install a suitable vinyl hose onto the injector to prevent gasoline from splashing out.  
 (i) Using SST, connect terminals + B and FP of the check connector.

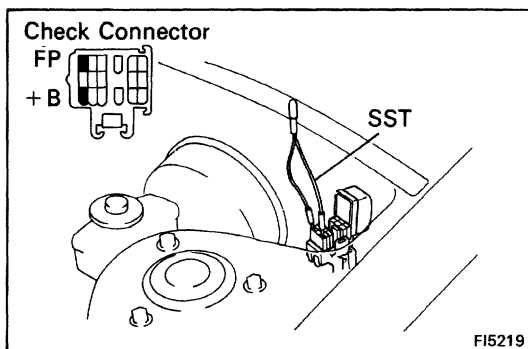

- SST 09843-18020  
 (j) Reconnect the battery negative (-) cable.  
 (k) Turn the ignition switch ON.  
**NOTICE: Do not start the engine.**

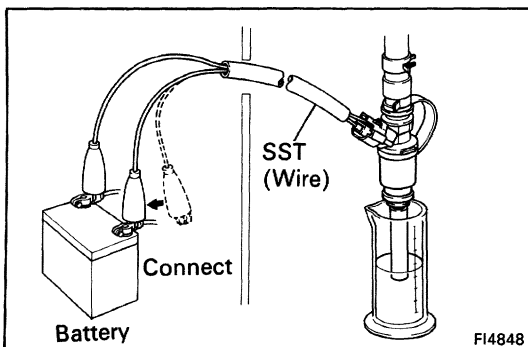

- (l) Connect SST (wire) to the injector and battery for 15 seconds, and measure the injection volume with a graduated cylinder. Test each injector two or three times.  
 SST 09842-30070  
**Volume: 40 - 50 cc (2.4 - 3.1 cu in.) per 15 sec.**  
**Difference between each injector:**  
**5 cc (0.3 cu in.) or less**

If the injection volume is not as specified, replace the injector.

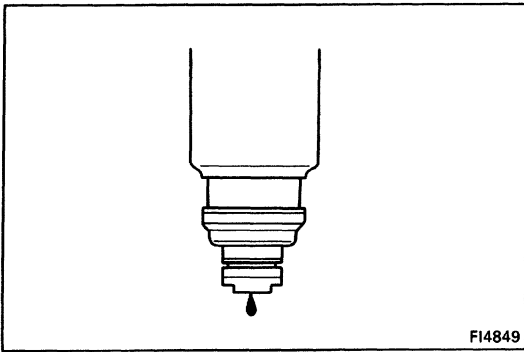

## 2. INSPECT LEAKAGE

- (a) In the condition above, disconnect the test probes of SST (wire) from the battery and check the fuel leakage from the injector.

SST 09842-30070

**Fuel drop: One drop or less per minute**

- (b) Disconnect the battery negative (-) cable.

- (c) Remove SST.

SST 09268-41045 and 09843-18020

## INSTALLATION OF INJECTORS

### 1. INSTALL INJECTORS AND DELIVERY PIPE

- (a) Install a new grommet to the injector.

- (b) Apply a light coat of gasoline to a new O-ring and install it to the injector.

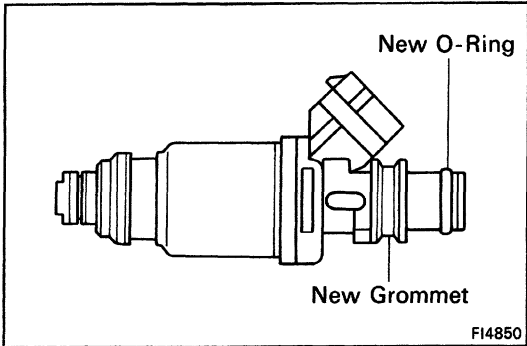

- (c) While turning the injector left and right, install it to the delivery pipes. Install the four injectors.

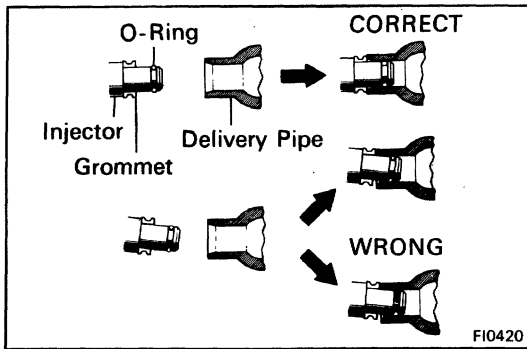

- (d) Place four new insulators and the two spacers in position on the cylinder head.

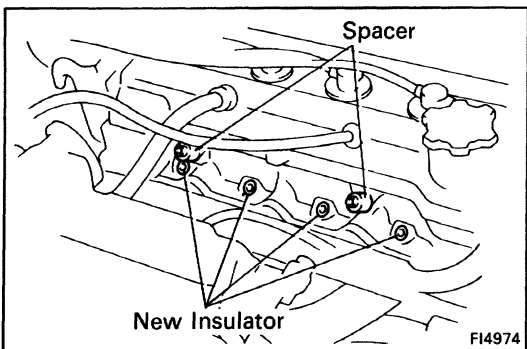

- (e) Place the four injectors together with the delivery pipe in position on the cylinder head.

- (f) Check that the injectors rotate smoothly.

HINT: If injectors do not rotate smoothly, the probable cause is incorrect installation of O-rings. Replace the O-rings.

- (g) Position the injector connector upward.

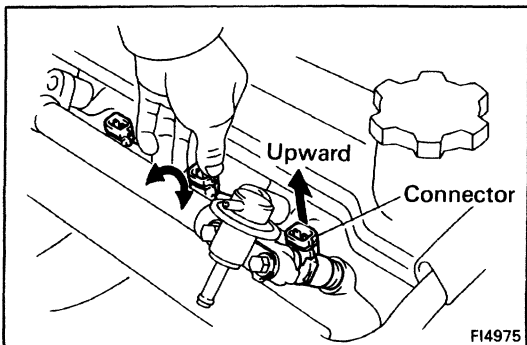

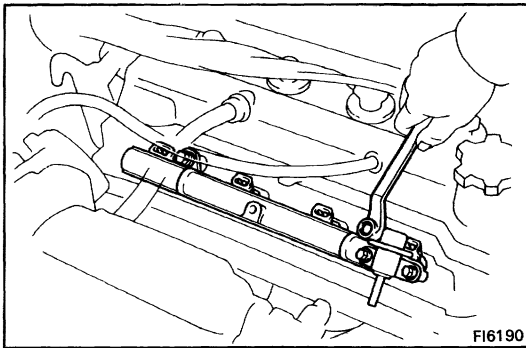

(h) Install the two bolts.

**Torque: 150 kg-cm (11 ft-lb, 15 N-m)**

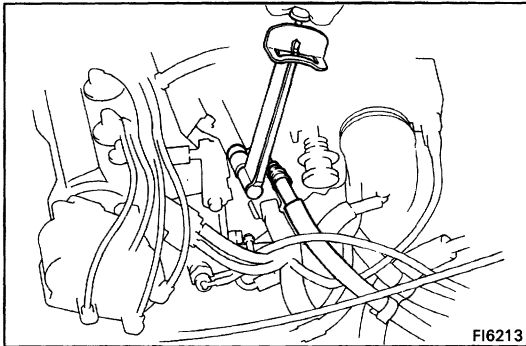

## **2. CONNECT FUEL INLET HOSE TO DELIVERY PIPE**

Connect the inlet hose with two new gaskets and the union bolt.

**Torque: 300 kg-cm (22 ft-lb, 29 N-m)**

## **3. CONNECT INJECTOR CONNECTORS**

## **4. CONNECT FUEL RETURN HOSE TO FUEL PRESSURE REGULATOR**

## **5. CONNECT VACUUM SENSING HOSE TO FUEL PRESSURE REGULATOR**

## **6. CONNECT CABLE TO NEGATIVE TERMINAL OF BATTERY**

## **7. CHECK FOR FUEL LEAKAGE (See page [FI-10](#))**