

Cylinder Heads

Removal

1. Rotate crankshaft (6303) to zero degrees top dead center (TDC) on the compression stroke.
2. Disconnect battery ground cable (14301) .
3. Drain engine cooling system. Refer to [Section 03-03](#).
4. Remove air cleaner outlet tube (9B659) to throttle body (9E926) . Refer to Section 03-12.
5. Mark and remove vacuum lines to upper intake manifold (9424) .
6. Disconnect EGR backpressure transducer hose from EGR valve to exhaust manifold tube (9D477) , loosen lower EGR valve to exhaust manifold tube nut and rotate EGR valve to exhaust manifold tube away from EGR valve (EGR valve) (9D475) .
7. Disconnect the throttle position sensor (TP sensor) (9B989) , idle air control valve (IAC valve) (9F715) , EGR backpressure transducer and EGR vacuum regulator solenoid electrical connectors.
8.  **WARNING: COVER FUEL PRESSURE RELIEF VALVE (9H321) WITH SHOP CLOTH TO PREVENT ACCIDENTAL FUEL SPRAY INTO EYES.**
Relieve pressure at the fuel pressure relief valve . Refer to [Section 03-04A](#).
9. Remove fuel tube safety clips.
10.  **CAUTION: Cover fuel tube ends with clean shop cloths to prevent dirt from entering opening.**
Disconnect fuel tubes (9291) . Refer to [Section 10-01](#).
11. Remove upper intake manifold as described. Discard old intake manifold upper gasket (9H486) .
12. Disconnect engine control sensor wiring retainers from rocker arm cover stud bolts and each fuel injector, and position the engine control sensor wiring (12A581) out of the way.
13. **NOTE: Fuel injectors and fuel injection supply manifold (9F792) may be removed with lower intake manifold as an assembly.**
Remove fuel injection supply manifold and fuel injector.
14. Remove ignition wires from spark plugs (12405) . Refer to [Section 03-07A](#). Remove wire harness retainers from valve cover retaining stud bolts.
15. Remove ignition coil (12029) and bracket from LH front cylinder head (6049) and set aside. Refer to [Section 03-07A](#).
16. Disconnect upper radiator hose (8260) and heater water hoses (18472) .
17. Remove camshaft position sensor (CMP sensor) (6B288) and housing. Refer to [Section 03-14](#).
18. Disconnect engine control sensor wiring from engine coolant temperature sensor (ECT sensor) (12A648) and the water temperature indicator sender unit (10884) .
19. If LH (front) cylinder head is being removed, perform the following:
 - Disconnect generator electrical connectors.
 - Remove drive belt (8620) . Refer to [Section 03-05](#).
 - Remove drive belt tensioner (6B209) . Refer to [Section 03-05](#).
 - Remove generator brace and generator (GEN) (10346) .
 - Remove power steering support bracket and power steering pump (3A674) as an assembly and set aside in a position to prevent fluid from leaking out.
 - Remove oil level indicator tube retaining nut from exhaust manifold stud bolt. Rotate or remove oil level indicator tube (6754) from exhaust manifold (9430) .
20. If RH (rear) cylinder head is being removed, perform the following:
 - Remove intake manifold support (9J444) .
21. Remove valve covers (6582) as described.
22. **NOTE: Regardless of cylinder head removal order, the No. 3 cylinder intake valve push rod (6565) must be removed to allow removal of lower intake manifold .**
Loosen rocker arm seat retaining bolts enough to allow the rocker arm (6564) to be lifted off the push rod and rotated to one side.
23. Remove push rods . Identify the position of each push rod . The push rods should be installed in their original position during reassembly.
24. Remove lower intake manifold as described in this section.
25. Remove spark plugs .
26. Remove exhaust manifolds as described.
27. Remove cylinder head retaining bolts and discard.
28. Remove cylinder heads .
29. Remove and discard the old head gaskets (6051) .

Installation

1. **CAUTION:** Use care when scraping aluminum surfaces to prevent gouging which may cause leak paths.

NOTE: Lightly oil all bolt and stud bolt threads with Motorcraft Super Premium 5W30 Motor Oil XO-5W30-QSP or equivalent meeting Ford specification WSS-M2C153-G before installation except those specifying special sealant.

Place shop cloth in valve tappet valley to catch any dirt or gasket material. Clean cylinder head, intake manifold, valve cover and head gasket surfaces. If the cylinder head was removed for a head gasket replacement, check the flatness of the cylinder head and cylinder block gasket surfaces. Refer to [Section 03-00](#).

2. Position new head gaskets, noting UP designation on head gasket face, on cylinder block (6010) using the cylinder head to block dowel (6A008) for alignment.
3. **NOTE:** Replace cylinder head to block dowel if damaged.

Position cylinder heads on cylinder block over cylinder head to block dowels.

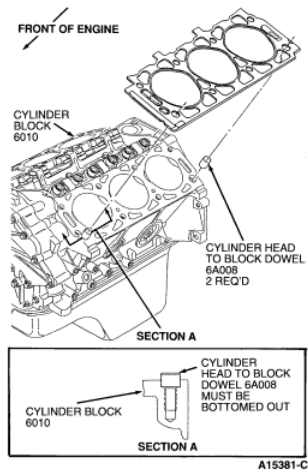

4. **CAUTION:** Always use new cylinder head bolts when installing cylinder head or damage to engine may occur.

Install new cylinder head retaining bolts. Tighten retaining bolts in sequence shown:

- 50 Nm (37 lb-ft).
- Then back off bolts 360 degrees.

5. **NOTE:** When cylinder head retaining bolts have been tightened as described, it is not necessary to retighten the bolts after extended engine operation.

Tighten the cylinder head retaining bolts in three final tightening steps in sequence shown in the following illustration:

- 30 Nm (22 lb-ft).
- Rotate 90 degrees.
- Rotate an additional 90 degrees.

Cylinder Head Bolt Installation Sequence

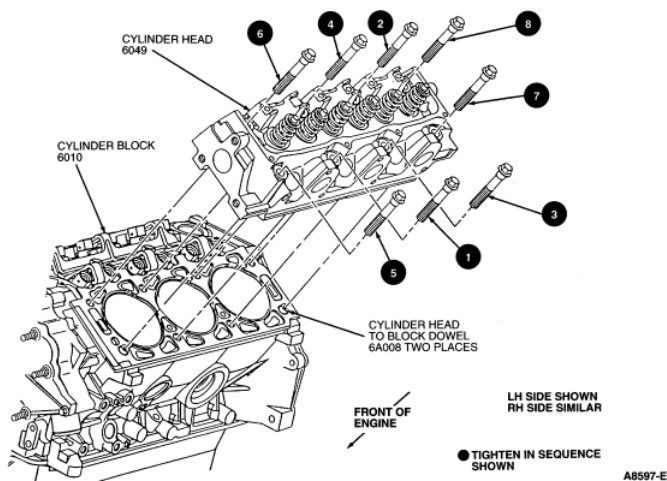

6. Install lower intake manifold as described. Connect engine control sensor wiring to the engine coolant temperature sensor and to the water temperature indicator sender unit.
7. Dip each push rod end in Engine Assembly Lubricant D9AZ-19579-D or equivalent meeting Ford specification ESR-M99C80-A. Install push rods in their original position.

Camshaft Position

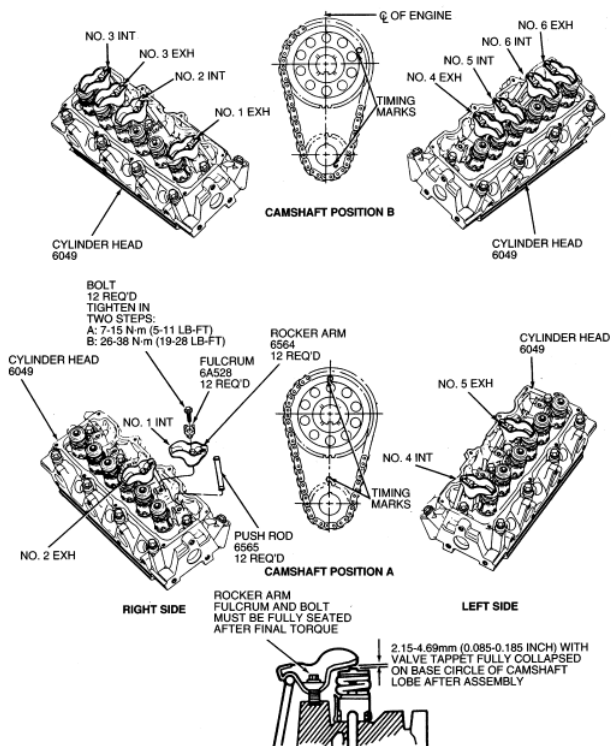

8. Rotate crankshaft clockwise one full turn (360 degrees). Install rocker arms , rocker arm seats (6A528) and retaining bolts as specified in camshaft position A. Tighten bolts to 7-15 Nm (6-11 lb-ft) to position rocker arm seats . Rotate crankshaft clockwise 120 degrees to camshaft position B. Install rocker arms , rocker arm seats and retaining bolts as specified in camshaft position B. Tighten bolts to 7-15 Nm (6-11 lb-ft).
9.  **CAUTION: Rocker arm seats must be fully seated in cylinder head and push rods must be seated in rocker arm and valve tappet sockets prior to final tightening.**
 Final tighten rocker arm seat retaining bolts to 26-38 Nm (20-28 lb-ft) with camshaft (6250) in any position.
10. **NOTE: If the original valve train components are being installed, a valve clearance check is not required. If a component has been replaced, perform a valve clearance check.**
 Lubricate all rocker arms with Engine Assembly Lubricant D9AZ-19579-D or equivalent meeting Ford specification ESR-M99C80-A.
11. Install lower intake manifold as described.
12. Install spark plugs if removed. Refer to [Section 03-07A](#).
13. Position valve covers on the cylinder heads and install retaining bolts. Note the location of ignition wire retainer stud bolts.
14. Connect engine control sensor wiring to fuel injectors and valve cover stud bolts.
15. Install upper intake manifold and intake manifold upper gasket .
16. Install ignition coil and bracket assembly. Tighten retaining bolts to 40-55 Nm (30-40 lb-ft).
17. Connect ignition wires to the spark plugs and ignition wire separators (12297) to valve cover retaining stud bolts. Install camshaft position sensor . Refer to [Section 03-14](#).
18. Connect intake air temperature sensor (IAT sensor) (12A697) , throttle position sensor , idle air control valve and EGR backpressure transducer or EGR vacuum regulator solenoid electrical connectors.
19. If LH (front) cylinder head was removed, perform the following:
 - Install or rotate oil level indicator tube to exhaust manifold retaining stud bolt. Tighten nut to 16-20 Nm (12-14 lb-ft).
 - Install power steering support bracket and power steering pump assembly. Tighten retaining bolt to 40-55 Nm (30-40 lb-ft).
 - Install drive belt tensioner . Refer to [Section 03-05](#).

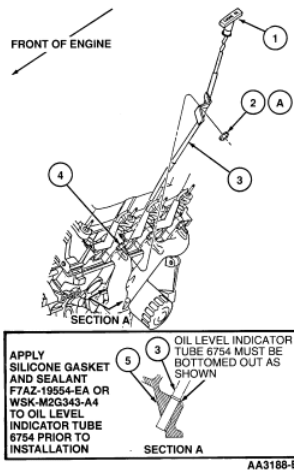

Item	Part Number	Description
1	6750	Oil Level Dipstick
2	N804944-S14	Nut
3	6754	Oil Level Indicator Tube
4	N808194-S431	Stud Bolt
5	6010	Cylinder Block
A	—	Tighten to 16-20 Nm (12-14 Lb-Ft)

20. If RH (rear) cylinder head was removed, install intake manifold support .
21. Install generator . Tighten long retaining bolt to 48 Nm (35 lb-ft) and short bolt to 37 Nm (27 lb-ft).
22. Install generator brace. Tighten retaining nut and bolt to 12-20 Nm (9-14 lb-ft).
23. Install the drive belt . Refer to [Section 03-05](#).
24. Connect fuel tubes . Refer to [Section 10-01](#).
25. Install fuel tube safety clips.
26. Connect upper radiator hose and heater water hoses . Tighten clamps securely.
27. Connect vacuum lines to premarked locations.
28. **CAUTION:** Engine coolant is corrosive to all engine bearing material. Replace engine oil after removal of a coolant carrying component to help prevent future failure.
Drain and change engine oil.
29. Install air cleaner outlet tube to throttle body and engine air cleaner (ACL) (9600) . Refer to [Section 03-12](#).
30. Install crankcase ventilation hose (6853) to valve cover . Refer to Section 03-08.
31. **CAUTION:** This engine has aluminum components and requires a special corrosion inhibiting coolant to avoid cooling system damage. Refer to [Section 03-03](#) for coolant specifications.
Fill and bleed engine cooling system. Refer to [Section 03-03](#).
32. Connect battery ground cable .
33. Start engine and check for coolant, fuel, oil, vacuum and exhaust leaks.
34. Check, and if necessary, adjust the accelerator cable (9A758) and speed control actuator cable (9A825) .

